

**THE RIVETING TOOL WITH 50 YEARS OF LEADERSHIP AND INNOVATION IN THE MAKING.**

**GESIPA INTRODUCES THE UNEQUALLED PERFORMANCE OF TAURUS.**

# TAURUS

**HYDRO-PNEUMATIC RIVETING TOOLS THAT COMBINE POWER, EFFICIENCY, SAFETY & ERGONOMICS**

## **Taurus Line:**

- 3 models covering a full range of diameters from 3/32" to 1/4" (2.4mm — 6.4mm)
- Optimized stroke length by model — matches the range of rivet sizes installed to maximize speed
- Steel, aluminum and polymer (composite) construction provides high power with low tool weight
- New 3-piece jaw design increases jaw life — reducing service costs
- Integrated mandrel collection system with grip release shutoff — conserves compressed air resources
- Gesipa's unique mandrel ejection feature redirects exhaust air to assist in spent mandrel collection
- Quick release quarter turn mandrel collector with safety interlock prevents tool operation when the container is removed
- Padded ergonomic tool grip enhances comfort — lowers operator fatigue
- Built-in retractable suspension loop for use with a tool support/balancer



# TAURUS

## PERFORMANCE SPECIFICATIONS

### TAURUS 2

<b>Working Range:</b>	up to 3/16" diameter Ø in all materials
<b>Weight:</b>	3.75 lbs.
<b>Pulling Strength:</b>	2,500 lbs. @ 90 psi
<b>Stroke:</b>	.709"
<b>Part #:</b>	757 0023



### TAURUS 1

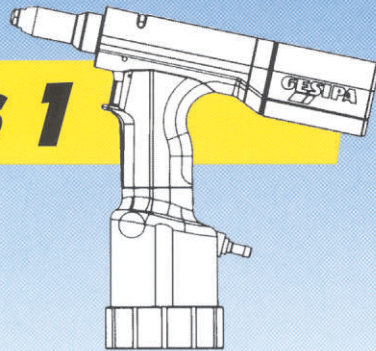

<b>Working Range:</b>	1/8" Ø in all materials 5/32" Ø alum/steel
<b>Weight:</b>	2.87 lbs.
<b>Pulling Strength:</b>	1,150 lbs. @ 90 psi
<b>Stroke:</b>	.590"
<b>Part # :</b>	756 0001

### TAURUS 3

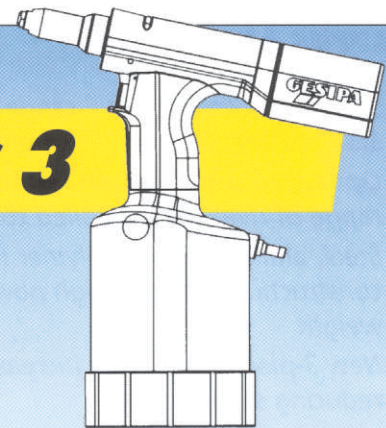

<b>Working Range:</b>	up to 1/4" Ø in all materials
<b>Weight:</b>	4.19 lbs.
<b>Pulling Strength:</b>	3,900 lbs. @ 90 psi
<b>Stroke:</b>	.984"
<b>Part # :</b>	758 0002